

GSE-6

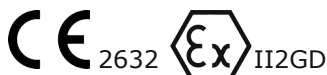

Ex dIIC T6 (85°C)
Ex tD A21 IP66 85°C
CEC 14 ATEX 098



- Microprocessor control
- 4 to 20 mA signal
- IP66 enclosure
- Sintered head
- Catalytic sensor technology
- Sensor active indicator
- Auto calibration
- From -20°C to +60°C

Reference Norms:
EN 1127-1:2007
EN 60079-0:2007
EN 60079-1:2008
EN 61241-0:2004
EN 61241-1:2006

Application

NRG Tech Srl is recognised within the gas industry for providing a comprehensive range of high reliability gas detection for many applications. We have installed and commissioned natural gas and carbon monoxide sensors in applications such as boiler rooms, kitchens, car parks, aircraft hangers, factories and shopping centres. The GSE-6 is the gas sensor ATEX certified used with the complete range of NRG Tech Srl detector panels. Every NRG Tech Srl product is manufactured to meet relevant European Normatives and proposals for explosive and toxic gases.

Operation

When the GSE-6 senses the presence of gas, it sends a 4 - 20mA signal to the gas control panel proportional to the level of gas. The panel then operates a prealarm relay - used for remote sirens or visual indicators if the level of gas continues to rise then the main alarm relay is activated to break the electrical supply to a safety shut off valve.

CAUTION! Carefully read the following instructions prior to installation of this device. Always keep this pamphlet for future reference.

Ensure that the gas detection system is wired correctly and is only used for the purpose for which it is intended.

Features

The GSE-6 is controlled by a microprocessor. This conducts both self diagnostics and automatically calibrates the sensor when ambient conditions vary, thus avoiding false alarms. A hand-held datalogger can be connected to the GSE-6 and information about the sensor can be read and printed out i.e.:

- the serial number
- the sensor condition
- how many times the sensor has been powered up
- how many alarms have occurred
- how many days of anticipated life remain
- how many auto adjusts have been made and
- the preset calibration state

Diagrams

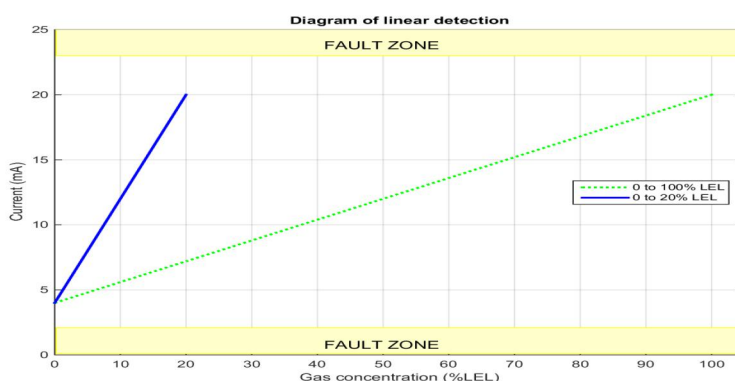

Liability limitations

- NRG Tech S.r.l. cannot be held liable to any person in regard to material damages, injuries or death of the user resulting entirely or partially from misuse, wrong installation or storage of the product non conforming with the instructions and warnings and/or non conforming with the norms and regulations in force.

- NRG Tech S.r.l. does not support nor authorizes any other company, person or legal entity to take on the part of responsibility assigned to NRG Tech S.r.l., even if involved in the sale of the products of NRG Tech S.r.l.

- NRG Tech S.r.l. shall not be held liable for the direct or indirect damages, as well as for the compensation of direct or indirect damages, resulting from the sale and use of its products, when such products were not specified and allowed by NRG Tech S.r.l. for a specific usage.

Particular Specifications for Use in Explosive Atmospheres in conformance with the European Directive ATEX 2014/34/EU.

NRG's sensors conform with the European Directive ATEX 2014/34/EU concerning explosive atmospheres. The sensors CANNOT be used for explosive gas measurement as safety devices, according to the Directive ATEX 2014/34/EU.

The information reported in the following paragraphs, shall be taken into consideration and observed by the person responsible of the product installation site.

Please refer to the provisions of the European Directive ATEX 1999/92/CE relevant to the improvement of security and health protection of workers who are exposed to the risks of explosive atmospheres.

Specifications for mechanical and electrical installations in a Classified Zone

The installation shall be performed according to current regulations, in particular the following norms: EN 60079-14 - EN 60079-17.

Explosion proof detectors (d)

- These instruments have been specially designed for ground-level industries II, Category 2 zone 1 and 2 (Gas) and zone 21 or 22 (Dusts).
- The instruments should be fitted with an ATEX cable input with the following mark: Ex d IIC.
- The working temperatures are between -20°C and +60°C, in the T6 temperature class.
- The cables should be mechanically protected.
- The sensor body should be grounded and connected to the external or internal terminal that must be protected against corrosion. The user should regularly clean the product in order to avoid any dust accumulation on its walls.
- The sensors should be installed mechanically so that the detection cell is facing down.
- If the connections are located in a classified zone, they should be protected in certified cases.
- Close the enclosure with a minimum of five rotations clockwise.

Positioning Sensors

The GSE-6 sensor should be mounted in accordance with certain considerations. Do not position next to burners, heaters or ovens where temperatures above the room ambient may be experienced. It is, if possible, better to mount the sensors on the opposite wall. This is, of course, dependant on the size of the protected area. The following picture indicates installation height for various types of gases (dimensions in mm).

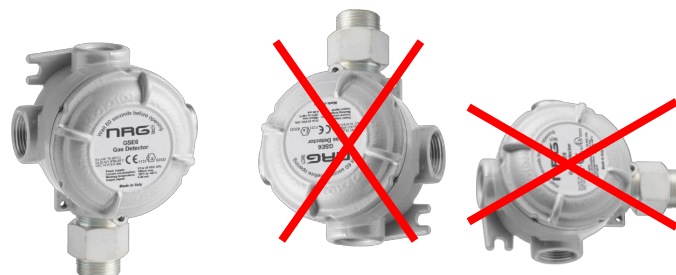
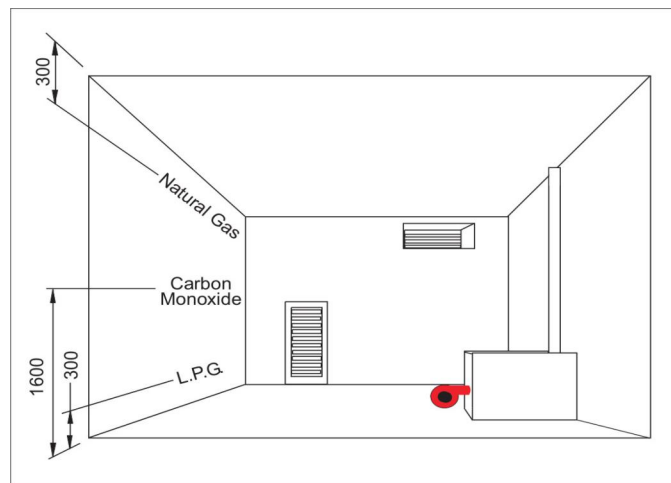

Gas Test

The general test should be performed by issuing gas from a pre-calibrated cylinder with exact volume percentages. In order to ensure the safe and accurate operation of fixed gas detectors, they need to be calibrated every six months although the frequency may need to be increased where continual exposure to the target gases is experienced. Between calibrations it is also recommended that the response of the detector is checked using an appropriate test gas cylinder. These cylinders are available in 'large aerosol' form and may be supplied individually or as part of a field calibration kit.

Replacing Sensors

When replacing the sensing element, perform the first calibration in clean air as per the instructions in the manual of the new sensing element. Do not exchange the head containing the sensitive element between the detectors without performing the calibration procedure.



Technical Specifications

Supply	12÷24 VCC +/- 10%
Current consumption	90 mA Max @12V
Sensor technology	Catalytic
Sensor working range	0÷100% of L.E.L.
Detector range	0÷100% L.E.L. (0÷20% L.E.L. on request)
Typical lifetime of sensing element	5 years
Output signal	4÷20 mA
Detector accuracy	+/- 1 % FS
Response time	< 30s
Functioning humidity	0-80% non condensed
Functioning temperature	from -20°C to +60°C
Max distance from control panel	100 m
Cable diameter	1 mm
Cable type	Shielded
Body material	Die-cast aluminium
Type of thread.....	3/4" NPT
External degree of protection	IP66

PCB Layout

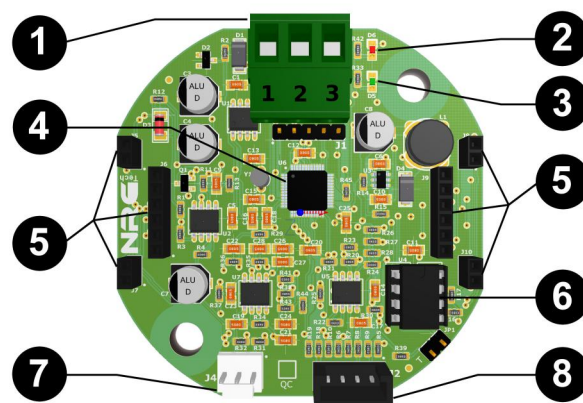

- 1- Main connection with the control unit. It receives power from pin 1 (positive) and pin 2 (negative) and send a current signal through the pin 3.
- 2- Red LED. Illuminate when the pre or main alarm gas threshold has been reached.
- 3- Green LED. Lights when supply voltage is applied. This light flashes during self diagnostics start up.
- 4- 32bit microcontroller unit. Controls the whole system.
- 5- Optional daughterboard connections.
- 6- EEPROM for datalogger purposes (Not implemented for this release).
- 7- Verification tester connection.
- 8- Gas sensor connector.

Wiring Diagrams

Before connecting to the mains power, ensure the voltage is correct.

Carefully follow the instructions and the connections according to Regulations in force, keeping in mind that the signal cables should be laid separate from the power cables and of shielded type.

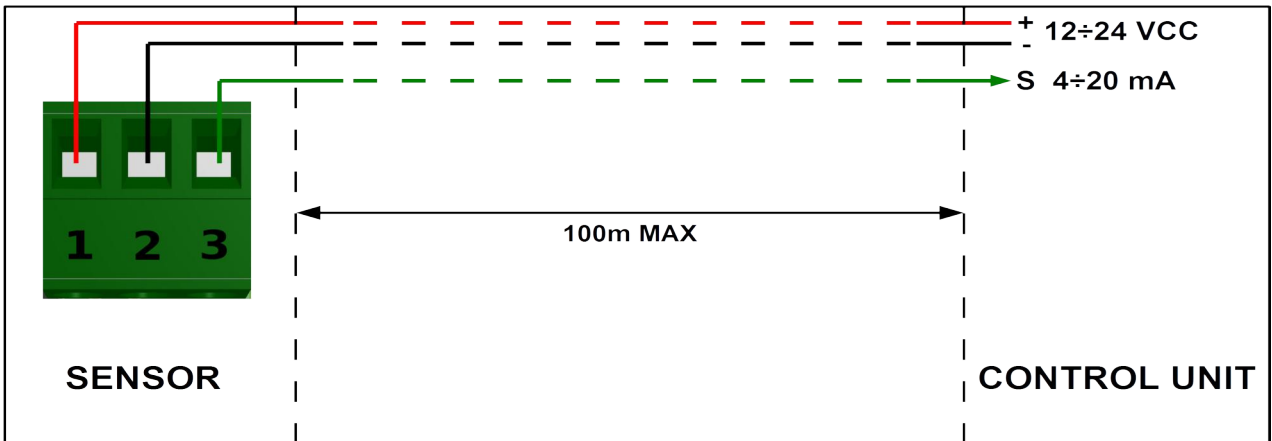

Overall dimensions

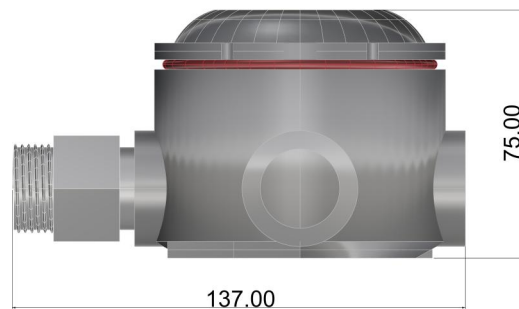
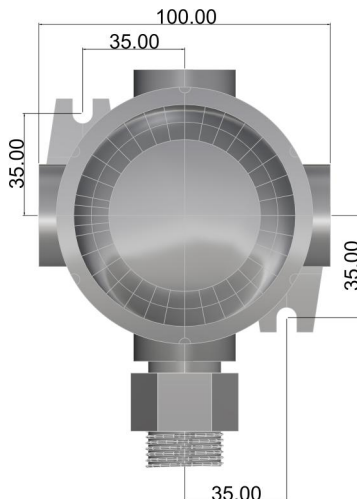

Warranty

The warranty term is 2 years from manufacturing date, in agreement with the following conditions. The components acknowledged as faulty will be replaced free of charge, excluding the replacement of plastic or aluminium cases, bags, packing, batteries and technical reports. The device must arrive free of shipment charges to the NRG Tech company. Defects caused by unauthorized personnel's tampering, incorrect installation and negligence resulting from phenomena outside normal functioning shall be excluded from the warranty.

The NRG Tech company is not liable for possible damage, direct or indirect, to people, animals or things, from product faults and from its enforced suspension of use.

NRG Tech S.r.l.
Via Primo Maggio, 23
35030 Bastia di Rovolon (PD) - ITALY
E-mail: info@nrgtech.it
Web: <http://www.nrgtech.it>

